

# Safety Door Lock Switch



## SFDL Series

For your safety, read and follow the considerations written in the instruction manual, other manuals and Autonics website.

The specifications, dimensions, etc. are subject to change without notice for product improvement. Some models may be discontinued without notice.

### Main Features

- Available to change the direction of inserting the operation key by rotating head  
: Inserting the operation key from 5 directions in the top and side
- Various kinds of contact composition  
: 4-contact (connected), 4-contact (not connected), 5-contact, 6-contact
- Selectable between connector type which reduces working process and separable terminal type which is useful for maintenance
- Manual unlock function (release key) to handle the emergency and test for safe installation  
: Cross type/special type release key line-up
- Minimized solenoid heat with stable current supply
- Excellent solidity/durability of metallic head
- Applicable to various applications using the slide key unit accessory

### Safety Considerations

- Observe all 'Safety Considerations' for safe and proper operation to avoid hazards.
- ⚠ symbol indicates caution due to special circumstances in which hazards may occur.

**⚠ Warning** Failure to follow instructions may result in serious injury or death.

- 01. Fail-safe device must be installed when using the unit with machinery that may cause serious injury or substantial economic loss.** (e.g. nuclear power control, medical equipment, ships, vehicles, railways, aircraft, combustion apparatus, safety equipment, crime/disaster prevention devices, etc.)  
Failure to follow this instruction may result in personal injury, economic loss or fire.
- 02. System manager means followings;**  
- a personnel who is fully aware of installation, setting, operation, and maintenance of the product  
- a personnel who well observes standard/regulation/statute on the product by type of machine the product installed in and nation/region the product used in  
Machine user means a personnel who is appropriately trained about using machine by the system manager, so that machine user can operate the machine correctly.  
System manager has duty to train the machine user about operation of the product.  
Machine user has to report directly to the system manager when unusual status has been found while system is operating.  
Failure to follow this instruction may result in personal injury, economic loss or fire.
- 03. The product has to be installed, set, and combined with machine control system by the qualified system manager.**  
Failure to follow this instruction may result in personal injury due to unintended operation and unstable detection.
- 04. Before using the product, check that function of the product operates as intended while machine is turned off after installation.**  
Failure to follow this instruction may result in personal injury due to unintended operation and unstable detection.
- 05. Do not use the unit in the place where flammable/explosive/corrosive gas, high humidity, direct sunlight, radiant heat, vibration, impact, salinity, moisture, or steam, or dust may be present.**  
Failure to follow this instruction may result in explosion or fire.
- 06. Do not disassemble or modify the unit.**  
Failure to follow this instruction may result in personal injury or fire due to loss of safety function.
- 07. Be cautious about the installing place of the operation key in order to protect worker from hitting the operation key when the door is opened.**  
Failure to follow this instruction may result in personal injury.
- 08. Do not use a head of the door switch (SFD Series).**  
Failure to follow this instruction may result in personal injury or fire due to loss of safety function.
- 09. Install separate safety device to fix door closed, or door can be opened because of vibration or weight of the door.**  
Failure to follow this instruction may result in personal injury.
- 10. Check the installed status of the switch, operating status of the switch, and signs of damage, modification, tampering of the switch at the following situation and on a weekly basis.**  
- when operating the safety system at first  
- when replacing component of the system  
- when the system has not been operated for a long time  
Failure to follow this instruction may result in personal injury due to malfunction of the product and safety function.
- 11. Solenoid Lock/Mechanical Release type switch is locked with power connected and is unlocked without power. Be cautious that the switch can be unlocked before complete stop of the machine when blackout occurs.**  
Failure to follow this instruction may result in personal injury.
- 12. Check 'Connections' before wiring.**  
Failure to follow this instruction may result in fire.

**⚠ Caution** Failure to follow instructions may result in injury or product damage.

- 01. Use the unit within the rated specifications.**  
Failure to follow this instruction may result in fire or product damage.
- 02. Since solenoid has polarity, wire cables and supply voltage ensuring correct polarity. Do not supply voltage above the rated voltage specification.**  
Failure to follow this instruction may result in fire or solenoid damage.
- 03. Use a dry cloth to clean the unit, and do not use water or organic solvent.**  
Failure to follow this instruction may result in fire.
- 04. Keep the door switch away from debris and tighten the screw securely when replacing the head.**  
Failure to follow this instruction may result in malfunction.
- 05. Keep the product away from metal chip, dust, and wire residue which might flow into the unit.**  
Failure to follow this instruction may result in fire, product damage or malfunction.
- 06. Do not use the switch as a guard door stopper. Install separate mechanical stopper.**  
Failure to follow this instruction may result in product damage.
- 07. Carefully manage the spare operation key in order to prevent use of the key without permission.**  
Failure to follow this instruction may result in loss of safety function due to insertion of the spare operation key.
- 08. Use only Autonics operation key.**  
Failure to follow this instruction may result in product damage.
- 09. Install the operation key tightly within the range written in 'Installation' with welding, rivet, or special bolt in order not to be easily released from the switch.**  
Failure to follow this instruction may result in product damage.

## Cautions during Use

- Follow instructions in 'Cautions during Use'. Otherwise, it may cause unexpected accidents.
- Use the switch with the dedicated controller. Do not use the switch with another controller randomly.
- When it comes to the Solenoid Lock/Mechanical Release model, make it to be locked by supplying power after the door is closed. If the power is supplied when the door is opened, the switch will not be locked.
- This unit may be used in the following environments.
  - Indoors (in the environment condition rated in 'Specifications')
  - Altitude max. 2,000m
  - Pollution degree 3
  - Installation category III
  - Enclosure Type I

## Sold Separately

- Operation key
- Slide key unit
- Connector cable for the connector type model

## Ordering Information

This is only for reference.  
For selecting the specific model, follow the Autonics web site.

SFDL - ① ② ③ - ④ ⑤ ⑥

### ① Lock/Release method

M: Mechanical Lock/Solenoid Release  
S: Solenoid Lock/Mechanical Release

### ② Contact

No-mark: 4-contct (connected)  
C: 4-contact (not connected)  
5: 5-contact  
6: 6-contact

### ④ Connection type

No-mark: Terminal type  
C: Connector type

### ⑤ Connection outlet specification

M20: M20 thread  
G1/2: G1/2 thread

### ⑥ Release key type

No-mark: Cross type  
K: Special type

### ③ Contact composition

	4-contact	5-contact	6-contact
<b>A</b>	Lock 1 N.C. / 1 N.O. + Door 1 N.C. / 1 N.O.	Lock 1 N.C. / 1 N.O. + Door N.C. 2 / N.O. 1	Lock 2 N.C. / 1 N.O. + Door 2 N.C. / 1 N.O.
<b>B</b>	Lock N.C. 2 + Door N.C. 1 / N.O. 1	Lock N.C. 2 + Door N.C. 2 / N.O. 1	Lock N.C. 3 + Door N.C. 2 / N.O. 1
<b>C</b>	Lock N.C. 1 / N.O. 1 + Door N.C. 2	Lock N.C. 1 / N.O. 1 + Door N.C. 3	Lock N.C. 2 / N.O. 1 + Door N.C. 3
<b>D</b>	Lock N.C. 2 + Door N.C. 2	Lock N.C. 2 + Door N.C. 3	Lock N.C. 3 + Door N.C. 3

## Dimensions

- Unit: mm, For the detailed dimensions of the product, follow the Autonics web site.

### Terminal type

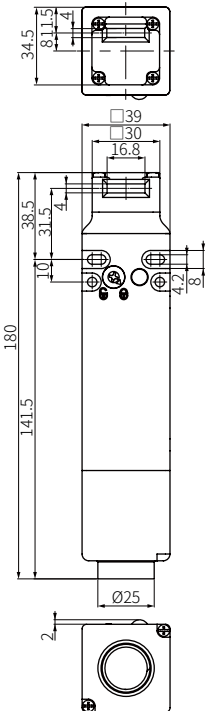

### Connector type

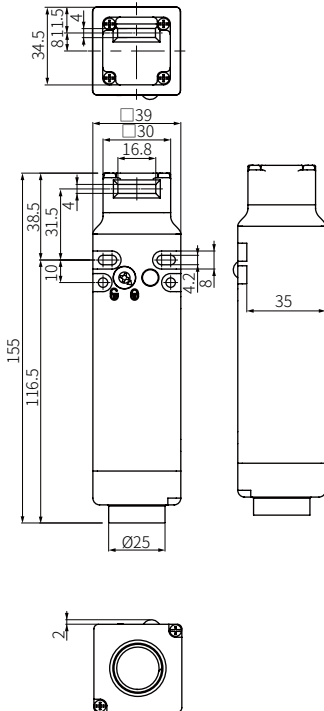

### Panel cut out

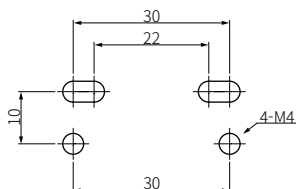

## Specifications

Model	SFDL-□□□-□□	SFDL-□□□-C□□
Directing opening force	≥ 80 N	
Directing opening distance	≥ 10 mm	
Locking pullout strength	≥ 1,300 N	
Operating speed	0.05 to 1 m/s	
Operating frequency	≤ 20/min	
Mechanical life cycle	≥ 1,000,000 operations (20/min)	
Vibration (malfunction)	0.35mm amplitude at frequency of 10 to 55 Hz (for 1 min) in each X, Y, Z direction for 10 min	
Shock	1,000 m/s <sup>2</sup> (≈ 100 G) in each X, Y, Z direction for 3 times	
Shock (malfunction)	80 m/s <sup>2</sup> (≈ 8 G) in each X, Y, Z direction for 3 times	
Ambient temperature	-10 to 55°C <sup>01)</sup> , storage: -25 to 65°C (a non freezing or condensation environment)	
Ambient humidity	35 to 85%RH, storage: 35 to 85%RH (a non freezing or condensation environment)	
Protection structure	IP67 <sup>02)</sup> (IEC standard, except for head)	
Material	Head: zinc, case: polyamide 66, operation key: stainless steel 304	
Approval	CE, RoHS, REACH, S	
Accessory	SFDL-□□□-□□□K (Special type release key) : rotating key	
Applicable cable	AWG22	-
Connection type	Terminal type	Connector type
Unit weight (packaged)	≈ 375 g (≈ 440 g)	≈ 325 g (≈ 395 g)

01) UL approved ambient temperature: 50°C

02) Rated protection structure is for the switch body. Be cautious about preventing the head part from entering the foreign materials such as dust and water.

### Contact block

Rated voltage/current for load	Resistive load: 1 A/120 VAC~, 0.22 A/125 VDC= Inductive load (IEC): AC-15 1 A/120 VAC~, DC-13 0.22 A/125 VDC= Inductive load (UL): C150, R150
Impulse dielectric strength	Between the terminals of same polarity: 1.5 kV Between the terminals of different polarity: 1.5 kV Between each terminal and non-live part: 2.5kV
Insulation resistance	≥ 100 MΩ (500 VDC= megger)
Contact resistance	≤ 200 mΩ
Electrical life cycle	≥ 100,000 operations (125 VAC~/1 A)
Conditional short-circuit current	100 A
<b>Solenoid</b>	
Rated voltage	24 VDC=, class 2
Current consumption	Supplying power: 0.26A Normal: max. 0.2A (approx. 3 seconds after supplying power)
Insulation class	Class E

## Installation

- The head of the switch can be rotated by loosening the four screws from the corners of the head and reinstalling the head in the desired orientation.
- Be sure to install the switch with the minimum radius at a hinged door as shown in the table.

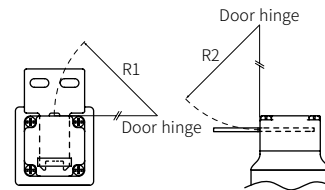

Operation key	Minimum radius R1	Minimum radius R2
SFD-KH	300 mm	300 mm
SFD-KL	300 mm	300 mm
SFD-KHR	300 mm	300 mm
SFD-KLR	300 mm	300 mm
SFD-KLF	50 mm	300 mm
SFD-KLF2	50 mm	300 mm

- Inspect the inserted operation key remains within the set zone (0.5 to 3 mm).
- Install the operation key within ±1 mm from the center of the operation key hole.

Set zone: 0.5 to 3 mm

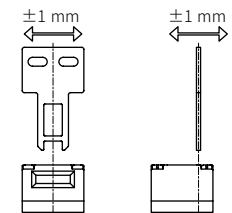
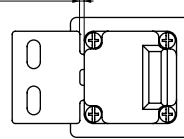

- Recommended screw tightening torque
- Cable gland specification and recommended product

Screw	Tightening torque
Terminal screw	0.4 Nm
Head mounting screw (M3)	0.7 to 0.9 Nm
Cable cover	0.5 to 0.7 Nm
Cable gland	2.7 to 3.3 Nm

Thread spec	MFR	Model
G1/2	LAPP	ST-PT1/2 5380-1002
M20	LAPP	ST-M20X1.5 5311-1020

- In case of using the cable gland with the 9 mm screw thread or longer, a gap between the switch and cable may affect the protection structure.
- Do not use metallic duct. Using metallic duct can result in electric shock due to the damage on the service entrance.

## Release Key

Release key type	Normal position	Manual unlock position
Cross type		
Special type		

- You can manually unlock the switch in the emergency situation such as blackout, when wiring, before supplying power, or when testing operation of the switch.
- When using the release key, turn it to the end completely. Otherwise (under 90°), switch can be damaged or malfunction.
- Do not apply the power over 0.2 Nm on the release key. It can be result in product damage.

## Contact Composition and Operation

Connection diagram represents the locked status with the operation key inserted.  
 (■: ON, □: OFF)

Model	Contact (lock monitor+ door monitor)	Connection diagram		Contact operation
		Lock monitor	Door monitor	
				Operation key complete insertion Operation key extraction
SFDL□A□□□□	1N.C./1N.O.+1N.C./1N.O.			Lock position 42-11 34-33 64-63
SFDL□B□□□□	2N.C.+1N.C./1N.O.			Lock position 42-11 34-33 62-61
SFDL□C□□□□	1N.C./1N.O.+2N.C.			Lock position 42-11 32-31 64-63
SFDL□D□□□□	2N.C.+2N.C.			Lock position 42-11 32-31 62-61
SFDL□CA□□□□	1N.C./1N.O.+1N.C./1N.O.			Lock position 42-11 22-21 34-33 64-63
SFDL□CB□□□□	2N.C.+1N.C./1N.O.			Lock position 42-11 22-21 34-33 62-61
SFDL□CC□□□□	1N.C./1N.O.+2N.C.			Lock position 42-11 22-21 32-31 64-63
SFDL□CD□□□□	2N.C.+2N.C.			Lock position 42-11 22-21 32-31 62-61
SFDL□5A□□□□	1N.C./1N.O.+2N.C./1N.O.			Lock position 42-11 22-21 34-33 64-63
SFDL□5B□□□□	2N.C.+2N.C./1N.O.			Lock position 42-11 22-21 34-33 62-61
SFDL□5C□□□□	1N.C./1N.O.+3N.C.			Lock position 42-11 22-21 32-31 64-63
SFDL□5D□□□□	2N.C.+3N.C.			Lock position 42-11 22-21 32-31 62-61
SFDL□6A□□□□	2N.C./1N.O.+2N.C./1N.O.			Lock position 42-11 52-21 34-33 64-63
SFDL□6B□□□□	3N.C.+2N.C./1N.O.			Lock position 42-11 52-21 34-33 62-61
SFDL□6C□□□□	2N.C./1N.O.+3N.C.			Lock position 42-11 52-21 32-31 64-63
SFDL□6D□□□□	3N.C.+3N.C.			Lock position 42-11 52-21 32-31 62-61

## Operation Key (sold separately)

• Unit: mm, For the detailed dimensions of the product, follow the Autonics web site.

### ■ SFD-KH

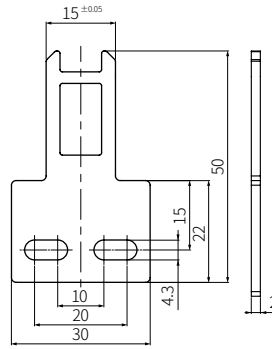

### ■ SFD-KL

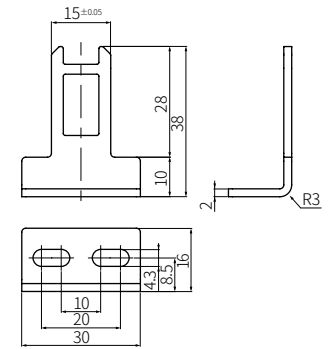

### ■ SFD-KHR

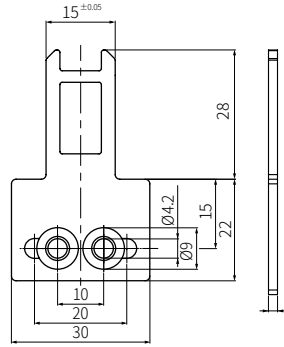

### ■ SFD-KLR

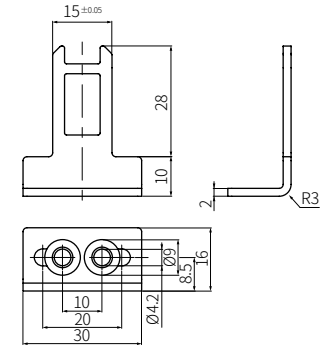

### ■ SFD-KLF, SFD-KLF2

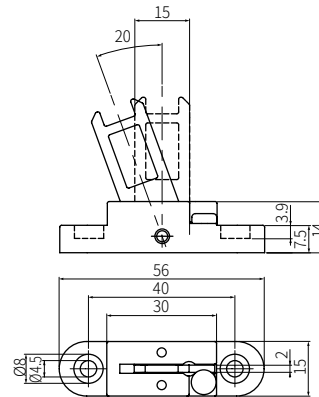

Model	Material
SFD-KLF	Operation key: stainless steel 304, base: polyamide
SFD-KLF2	Operation key: stainless steel 304, base: zinc

## Connector Cable (sold separately)

• Connector cable is the separately sold accessory for the connector type model.

Pin	Lead wire color
1	Black
2	Black/White
3	Red
4	Red/White
5	Green
6	Green/White
7	Yellow
8	Yellow/White
9 (E1)	Brown
10 (E2)	Brown/White

Model	L
SFDL-CND10-1	1m
SFDL-CND10-3	3m
SFDL-CND10-5	5m